



*The Signature of Quality*

### FEDERAL INDUSTRIES

A Standex Company  
215 Federal Avenue  
Belleville, WI 53508-9201

Phone: 800-356-4206  
Fax: 608-424-3234  
Email: geninfo@federalind.com  
Website: www.federalind.com

Project Name: \_\_\_\_\_

Item #: \_\_\_\_\_

Model #: \_\_\_\_\_ Qty: \_\_\_\_\_

Approval: \_\_\_\_\_

AIA#

SIS#

## MARKET SERIES HOT DELI CASE

**Market Deli. The low profile merchandiser that provides solutions to your fresh food merchandising needs. Designed for continuous case line-ups without middle end glass.**



Panel base shown.

MODEL	DIMENSIONS ( Includes End Panels )
<input type="checkbox"/> SQ3HD	36 x 44.125 x 48 (in) 914 x 1121 x 1219 (mm)
<input type="checkbox"/> SQ4HD	48 x 44.125 x 48 (in) 1219 x 1121 x 1219 (mm)
<input type="checkbox"/> SQ6HD	72 x 44.125 x 48 (in) 1829 x 1121 x 1219 (mm)
<input type="checkbox"/> SQ8HD	96 x 44.125 x 48 (in) 2438 x 1121 x 1219 (mm)

## STANDARD FEATURES

### Model Features

- Lift-up, pneumatic, cylinder-assisted curved front glass.
- Adjustable Leg Levelers
- Rear work counter.
- Pedestal or panel base design.
- Tempered front and end glass.
- Removable rear door assembly. Doors not required for operation.
- Stainless steel interior and exterior finish.
- Solid-state control panel with main power, light, zone well heaters, humidity and overhead heater settings. Panel also includes time and temperature readout.
- Zone heater controls.
- Designed for continuous case line-ups.
- Appliance receptacle provided on back for case register, scale or slicer.
- Auto water fill
- Humidified circulating air flow maintains ideal product moisture.
- Drain not required.

### Lighting

- Incandescent top light.

### Agency Approvals

- UL Safety and UL Sanitation listed.

## OPTIONAL ACCESSORIES

- |   |  |
|---|--|
| <input type="checkbox"/> Special Case Height (50" or 52")                 | <input type="checkbox"/> Scale Stand           |
| <input type="checkbox"/> Front Bumper Rail (Black, White, Green, Gray)    | <input type="checkbox"/> Food Container Holder |
| <input type="checkbox"/> Reflective End Glass                             | <input type="checkbox"/> Top Service Shelf     |
| <input type="checkbox"/> Decorative End Panel (Black, White, Green, Gray) | <input type="checkbox"/> Accent Base Light     |
|   | <input type="checkbox"/> Slicer Stand          |
|   | <input type="checkbox"/> Non-Glare Glass       |



**WARRANTY\***  
One year Parts and Labor  
2nd thru 5th year part  
only service compressor  
(U.S.A and Canada)



Note: Information is subject to change at any time.  
Visit [www.federalind.com](http://www.federalind.com) for the most current specs.

Revised 02/18/2020

AIA#

# MARKET SERIES HOT DELI CASE

SIS#

## Product Specifications

DIMENSION: xx"/(mm)

DIMENSION TOLERANCE +/- 0.25 (6.4)

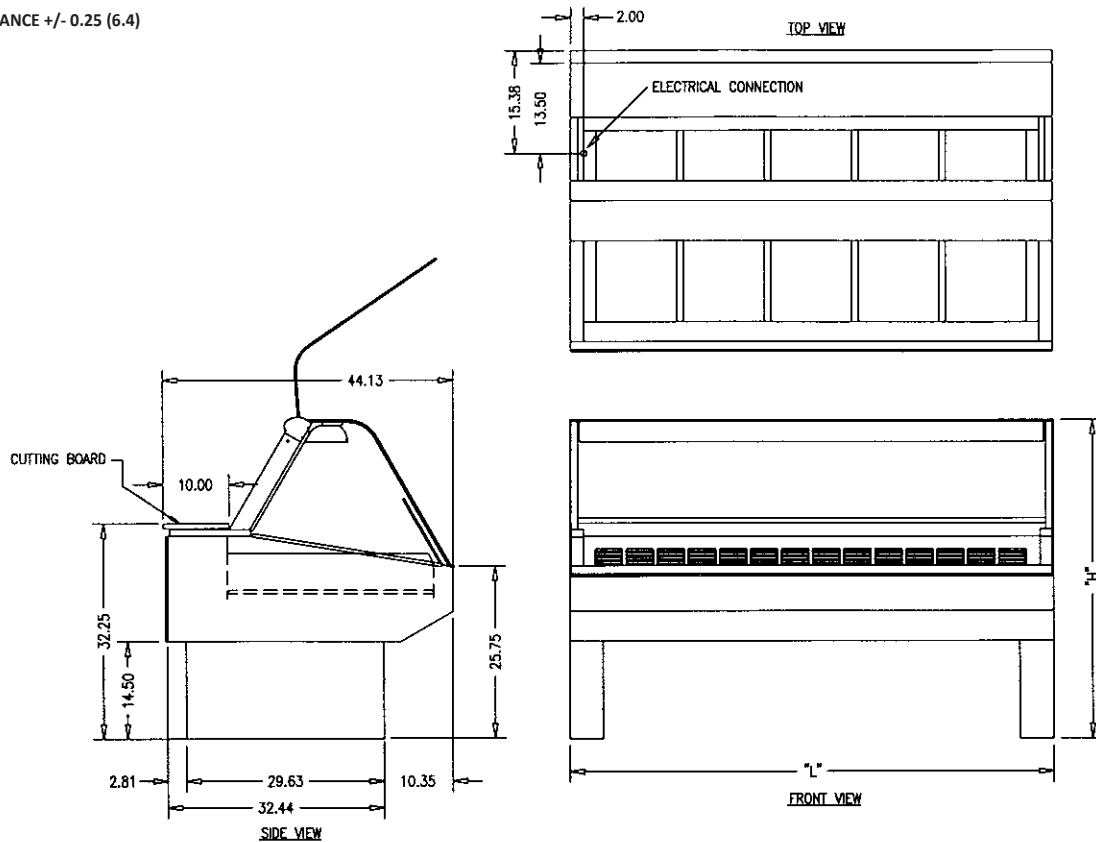

MODEL	* DIMENSIONS				SHIPPING WHT		** AMPS 120/208-240/60/1 3-WIRE PLUS GROUND	WATER CONNECTIONS	*** WELL CAPACITY
	L	D	H1	UNITS	LBS	KILO			
SQ3HD	36	44.125	48	in.	375	171	10.3	1/2" NPT	2
	1226	1121	1219	mm.					
SQ4HD	48	44.125	48	in.	470	213	14.6	1/2" NPT	3
	1219	1121	1219	mm.					
SQ6HD	72	44.125	48	in.	710	322	22.6	1/2" NPT	5
	1829	1121	1219	mm.					
SQ8HD	96	44.125	48	in.	920	417	31.2	1/2" NPT	7
	2438	1121	1219	mm.					

\* Without decorative end panels

\*\* Plus general receptacle 120V, 15 AMP. (2nd circuit required.) (n/a for Canadian Listings)

\*\*\* Each well holds a full-size pan and a third.

- When ordering, specify case line-up and pedestal or panel design
- Due to continuing engineering improvements, specifications are subject to change without notice.



The Signature of Quality®

**FEDERAL INDUSTRIES**

A Standex Company

215 Federal Avenue Belleville, Wisconsin 53508-9201

Phone: 800-356-4206

Fax: 608-424-3234

Email: [Geninfo@Federalind.com](mailto:Geninfo@Federalind.com)

Website: [Federalind.com](http://Federalind.com)